

4. Vestigial Sideband Modulation (VSB) (see page)

Single sideband modulation is well suited for the transmission of speech because of the **energy gap** that exists in the spectrum of speech signals between zero and a few hundred hertz. When the message signal contains significant components at extremely low frequencies(as in the case of television signals), the upper and lower sidebands **meet** at the carrier frequency.

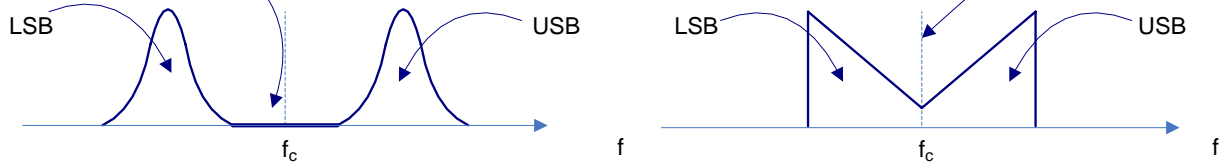

This means that the use of SSB modulation is inappropriate for the transmission of such message signals owing to the **practical difficulty of building a filter** to isolate one sideband completely.

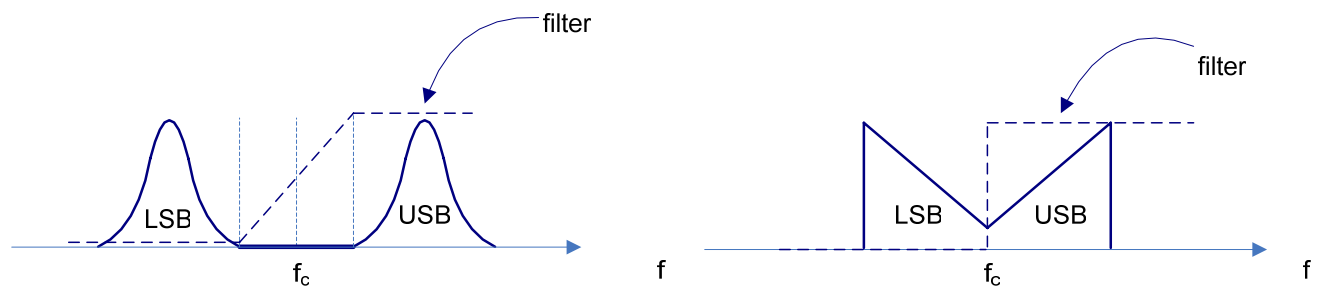

This difficulty suggests another scheme known as vestigial sideband modulation (VSB), which is a compromise between SSB and DSB-SC forms of modulation.

In VSB modulation, one sideband is passed almost completely whereas just a **trace** or vestige, of the other sideband is retained.

Figure 17 illustrates the spectrum of a VSB modulated wave $s(t)$ in relation to that of the message signal $m(t)$ assuming that the lower sideband is modified into the vestigial sideband.

Fig 17.

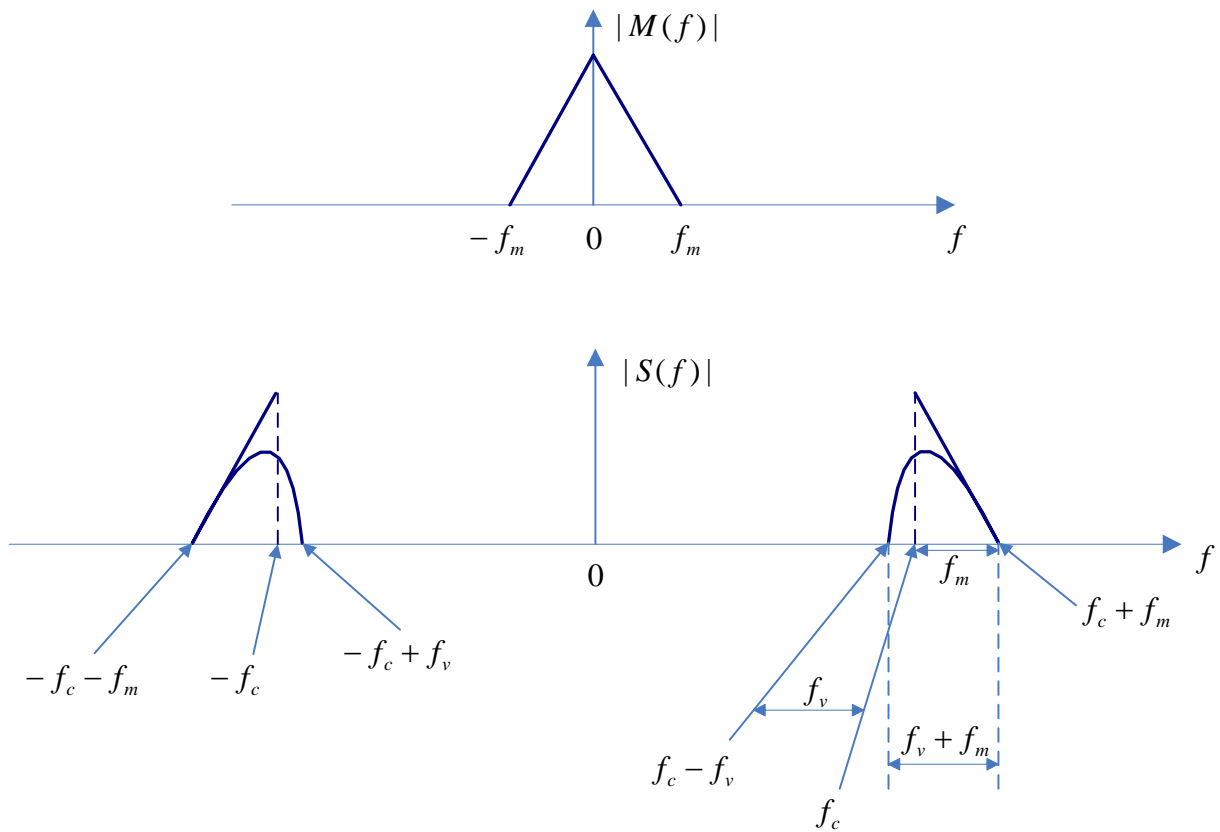

Specifically, the transmitted vestige of the lower sideband compensates for the amount removed from the upper sideband.

The transmission bandwidth (f_T) required by the VSB modulated wave is therefore

$$f_T = f_m + f_v$$

To generate a VSB modulated wave, we pass a DSB-SC modulated wave through a sideband shaping filter as in Fig 18.

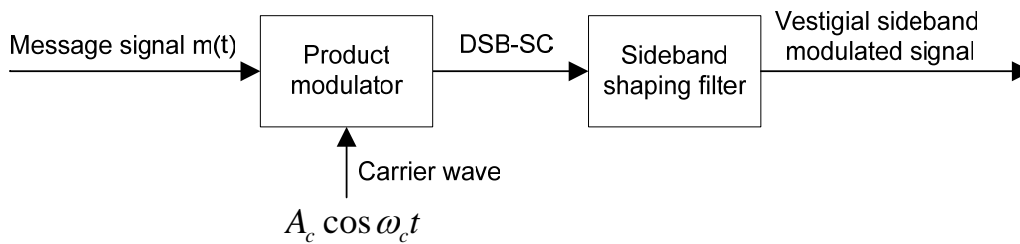
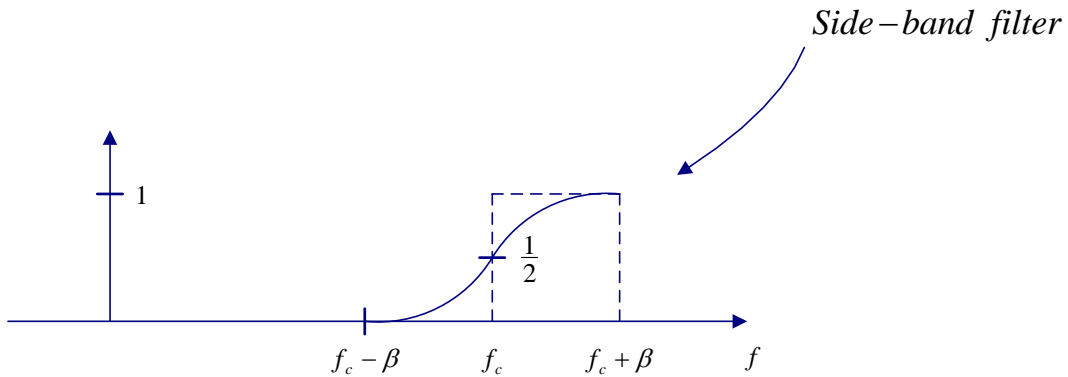

Fig 18.

The key to VSB is the sideband filter, a typical transfer function being shown below:



While the exact shape of the response is not crucial, it must have odd symmetry above the carrier frequency and a relative response of $\frac{1}{2}$ at f_c . The filter response is designed so that the original message spectrum $M(\omega)$ is reproduced on demodulation as a result of the superposition of two spectra:

On demodulation,

- The positive frequency part of $S(\omega)$ {i.e. spectrum of transmitted signal $s(t)$ } is shifted downward in frequency by f_c .
- The negative frequency part of $S(\omega)$ is shifted upward in frequency by f_c .

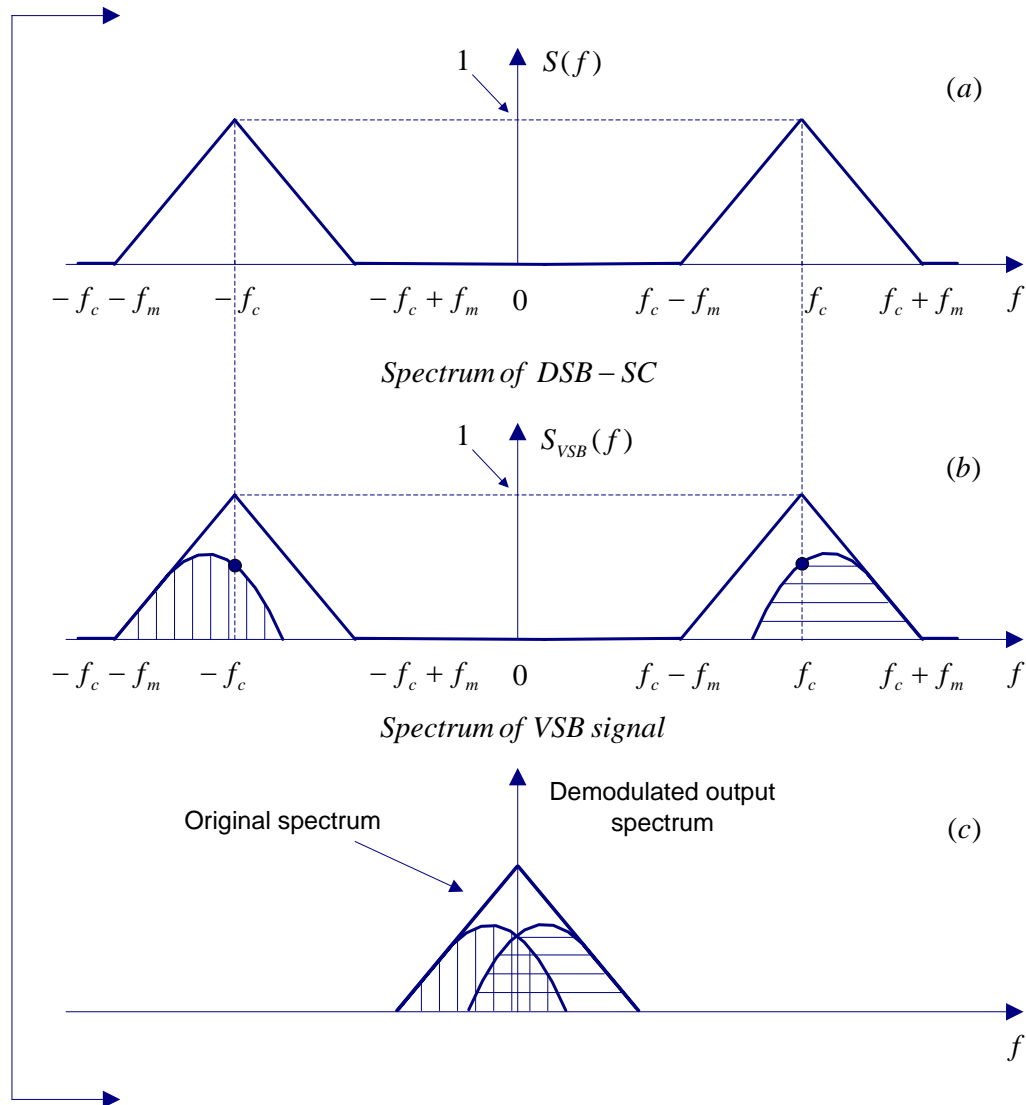

The magnitudes of these two spectral contributions are shown in (b) above. In effect, a reflection of the vestige of the lower sideband makes up for the missing part of the upper sideband. Vestigial sideband modulation has the virtue of conserving bandwidth almost as efficiently as single sideband modulation, while retaining the excellent low-frequency characteristics of double sideband modulation.

The VSB modulation has become standard for the analogue transmission of television and similar signals, where transmission of low-frequency components is important, but the bandwidth required for double sideband transmission is unavailable.

In the transmission of television signals in practice, a controlled **amount of carrier is added to the VSB modulated signal**. This is done to permit the use of an **envelope detector for demodulation**. The design of the receiver is thereby considerably simplified.

Example: Let the message signal be the sum of two sinusoids.

$$m(t) = A_1 \cos \omega_1 t + A_2 \cos \omega_2 t$$

The message signal is multiplied by a carrier $\cos \omega_c t$ to form the DSB signal.

DSB-SC



$$s(t) = (A_1 \cos \omega_1 t + A_2 \cos \omega_2 t) \cos \omega_c t$$

$$= \frac{1}{2} A_1 \cos(\omega_c - \omega_1)t + \frac{1}{2} A_2 \cos(\omega_c - \omega_2)t + \frac{1}{2} A_2 \cos(\omega_c + \omega_2)t + \frac{1}{2} A_1 \cos(\omega_c + \omega_1)t$$

Single sideband spectrum is shown below.

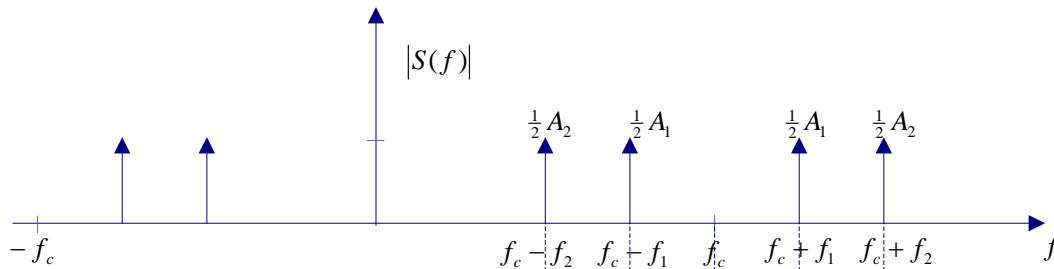

A vestigial sideband filter is then used to generate the VSB signal.

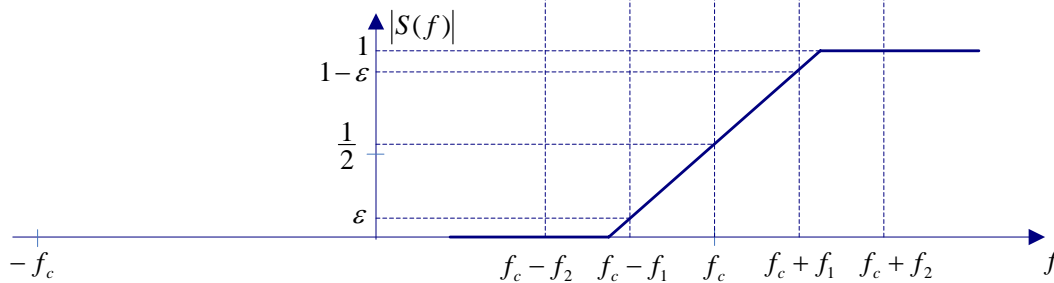

A vestigial sideband filter is then used to generate the VSB signal.

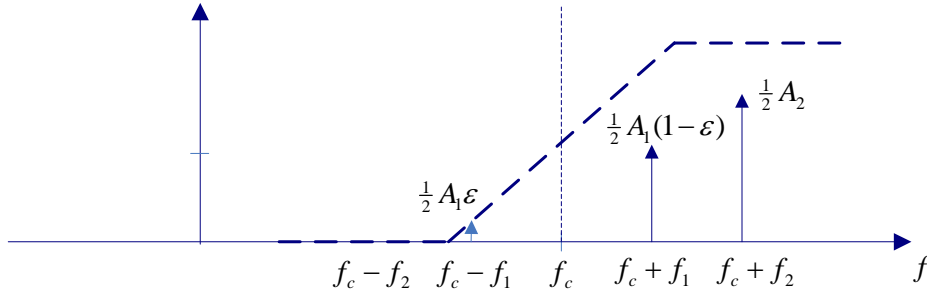

The spectrum of the VSB signal is

$$VSB_{\text{spectrum}} = |S(f)| \cdot |H(f)|$$

$$v_{VSB}(t) = \frac{1}{2} A_1 \cos(\omega_c - \omega_1)t + \frac{1}{2} A_1 (1 - \epsilon) \cos(\omega_c + \omega_1)t + \frac{1}{2} A_1 \cos(\omega_c + \omega_2)t$$

Demodulation:

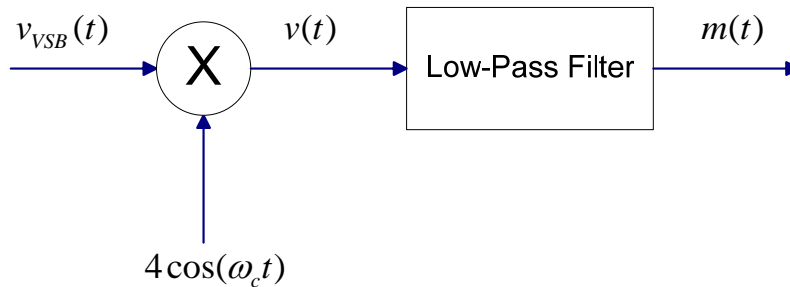

$$v(t) = v_{VSB}(t) \cdot 4 \cos \omega_c t =$$

$$2A_1 \epsilon \cos(\omega_c - \omega_1)t \cdot \cos \omega_c t + 2A_1 (1 - \epsilon) \cos(\omega_c + \omega_1)t \cdot \cos \omega_c t + 2A_2 \epsilon \cos(\omega_c + \omega_2)t \cdot \cos \omega_c t$$

$$= A_1 \epsilon [\cos(2\omega_c - \omega_1)t + \cos \omega_1 t] + A_1 (1 - \epsilon) [\cos(2\omega_c + \omega_1)t + \cos \omega_1 t] + A_2 [\cos(2\omega_c + \omega_2)t + \cos \omega_2 t]$$

After low-pass filtering,

$$m(t) = A_1 \epsilon \cos \omega_1 t + A_1 (1 - \epsilon) \cos \omega_1 t + A_2 \cos \omega_2 t$$

$$\Rightarrow \boxed{m(t) = A_1 \cos \omega_1 t + A_2 \cos \omega_2 t}, \text{ which is the assumed message signal.}$$

Receivers for AM radio broadcasting

Commercial AM radio broadcasting utilises frequency band 535-1605 KHz for transmission of voice and music.

The carrier frequency allocations range from 540-1600 KHz with 10 KHz spacing.

Radio stations employ conventional AM for signal transmission. The base-band message signal $m(t)$ is limited to a bandwidth of approximately 5KHz.

Since there are billions of radio receivers (radios) and relatively few radio transmitters, the use of conventional AM broadcast is justified –the major objective is to reduce the cost of implementing the radio receivers (radios).

The receiver most commonly used in AM broadcast is the so-called ‘**superheterodyne receiver**’ shown in Fig 20.

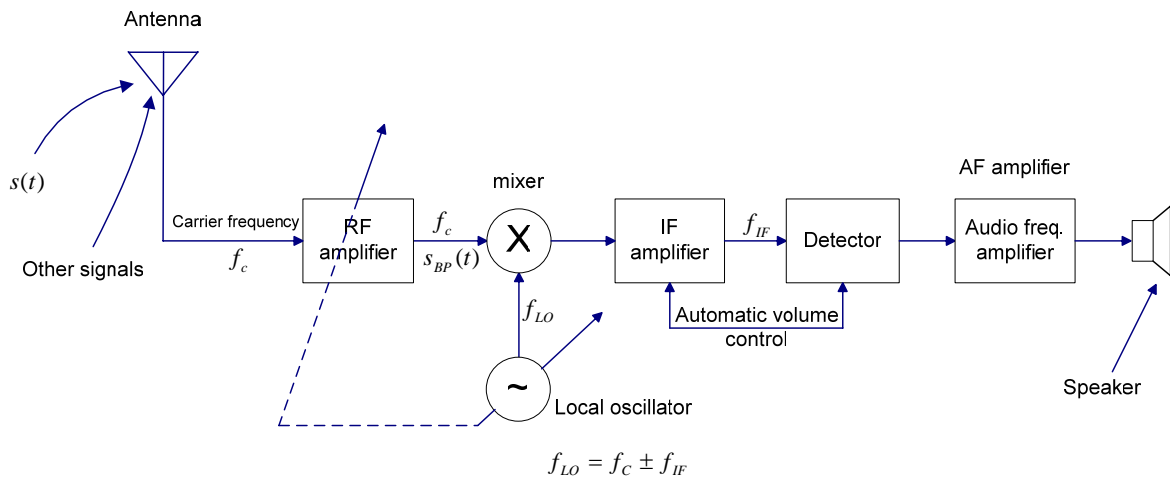

Fig 20.

It consists of:

- **A radio frequency (RF) tuned amplifier**
[The RF amplifier has a band-pass characteristics that passes the desired signal and provides amplification – Also provides some rejection of adjacent signals and noise].
- **A mixer (or frequency translator)**
[The multiplication of the band-pass signal $S_{BP}(t)$ and the local oscillator output is referred to as mixing].
- **A local oscillator**

[The local oscillator frequency tracks with the RF tuning such that $f_{LO} = f_c + f_{IF}$ or $f_{LO} = f_c - f_{IF}$ ($f_c > f_{IF}$).

- **An Intermediate Frequency (IF) amplifier**

[The mixer contents the RF output down to some convenient frequency band called the intermediate frequency (IF)].

The IF filter is a band-pass filter which provides most of the gain.

- **An envelope detector**

[Note that the envelope of the IF filter output is the same as the envelope for the RF input. Envelope detector recovers the message]

- **An audio frequency amplifier and a loudspeaker.**

In the superheterodyne receiver, every AM radio signal is converted to a common IF of $f_{IF} = 455 \text{ KHz}$. This conversion allows the use of a single tuned IF amplifier for signals from any radio station in the frequency band.

The IF amplifier is designed to have a bandwidth of 10 KHz, which matches the bandwidth of the transmitted signal.

The frequency conversion to IF is performed by the combination of the RF amplifier and the mixer.

The frequency of a local oscillator :

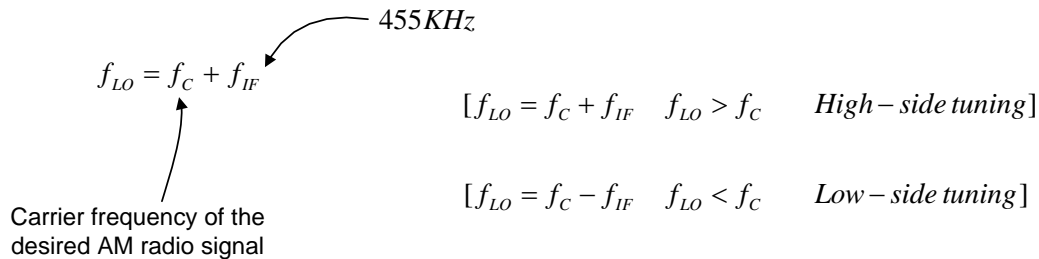

The tuning range of the local oscillator is 955- 2055 KHz [carrier: 540-1600 KHz]

By tuning the RF amplifier to f_c and mixing with $f_{LO} = f_c + f_{IF}$ we obtain two signal components:

- One centred at the difference frequency f_{IF} [i.e. $f_{LO} - f_c = f_c + f_{IF} - f_c = f_{IF}$]
- The second centred at the sum frequency $2f_c + f_{IF}$ [i.e. $f_{LO} + f_c = f_c + f_{IF} + f_c = 2f_c + f_{IF}$]

Only the 1st one will pass through the IF amplifier.

At the input of the RF amplifier we have signals picked up by the antenna from all radio stations.

By limiting the Bandwidth of the RF amplifier to the range,

$$\text{Transmission bandwidth} < \text{bandwidth } (B_{RF}) < 2 f_{IF}$$

(BT)

,where BT is the bandwidth of the AM radio signal (10KHz), we can reject the radio signal transmitted at the so-called **image frequency**,

$$f'_C = f_{LO} + f_{IF} \text{ [i.e. } f_{LO} = f'_C - f_{IF} \text{]}$$

What is image frequency?

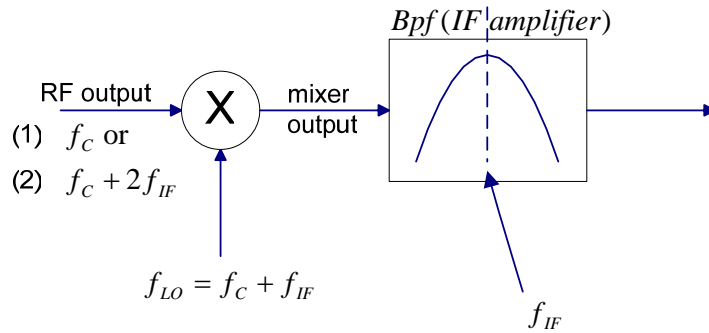

mixer output frequencies:

- (1) $f_c + f_{LO}$ & $f_{LO} - f_c$
 $= 2f_c + f_{IF}$ & f_{IF}
- (2) $f_c + 2f_{IF} + f_{LO}$ & $f_c + 2f_{IF} - f_{LO}$
 $= 2f_c + 3f_{IF}$ & f_{IF}

Note

If we are attempting to receive a signal having carrier frequency f_c , we will also receive a signal $f_c + 2f_{IF}$ if the local oscillator $f_{LO} = f_c + f_{IF}$.

$\therefore f_c + 2f_{IF}$ is known as the image frequency.

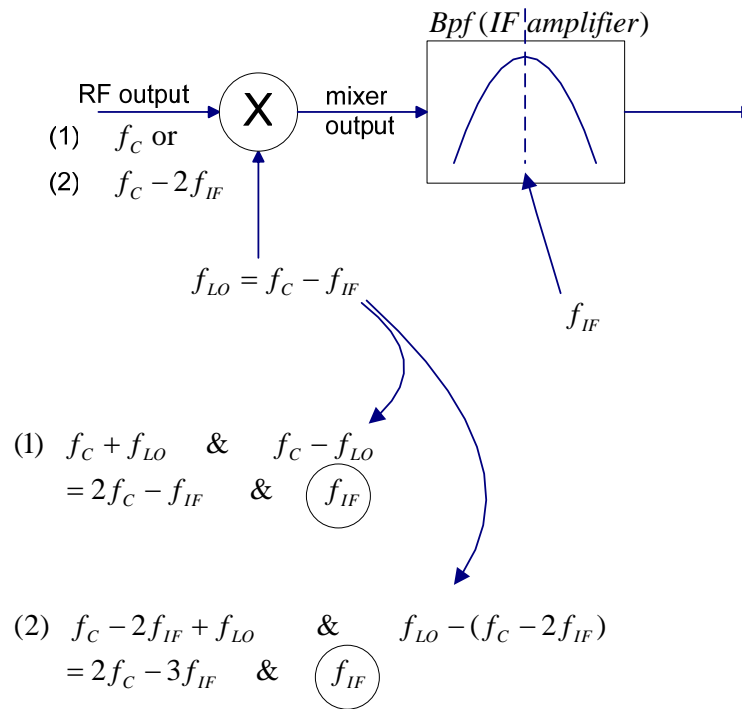

Note

If we are attempting to receive a signal having carrier frequency f_c , we will also receive a signal $f_c - 2f_{IF}$ if the local oscillator $f_{LO} = f_c - f_{IF}$
 $\therefore f_c - 2f_{IF}$ is known as the image frequency.

We have seen that there is only one image frequency, and it is always separated from the desired frequency by $2f_{IF}$.

The relationship between the desired signal to be demodulated and the image signal is summarised in Fig 21 for low-side and high-side tuning.

The desired signal to be demodulated has a carrier frequency of f_c and the image signal has a carrier frequency of f_i (see Fig 21).

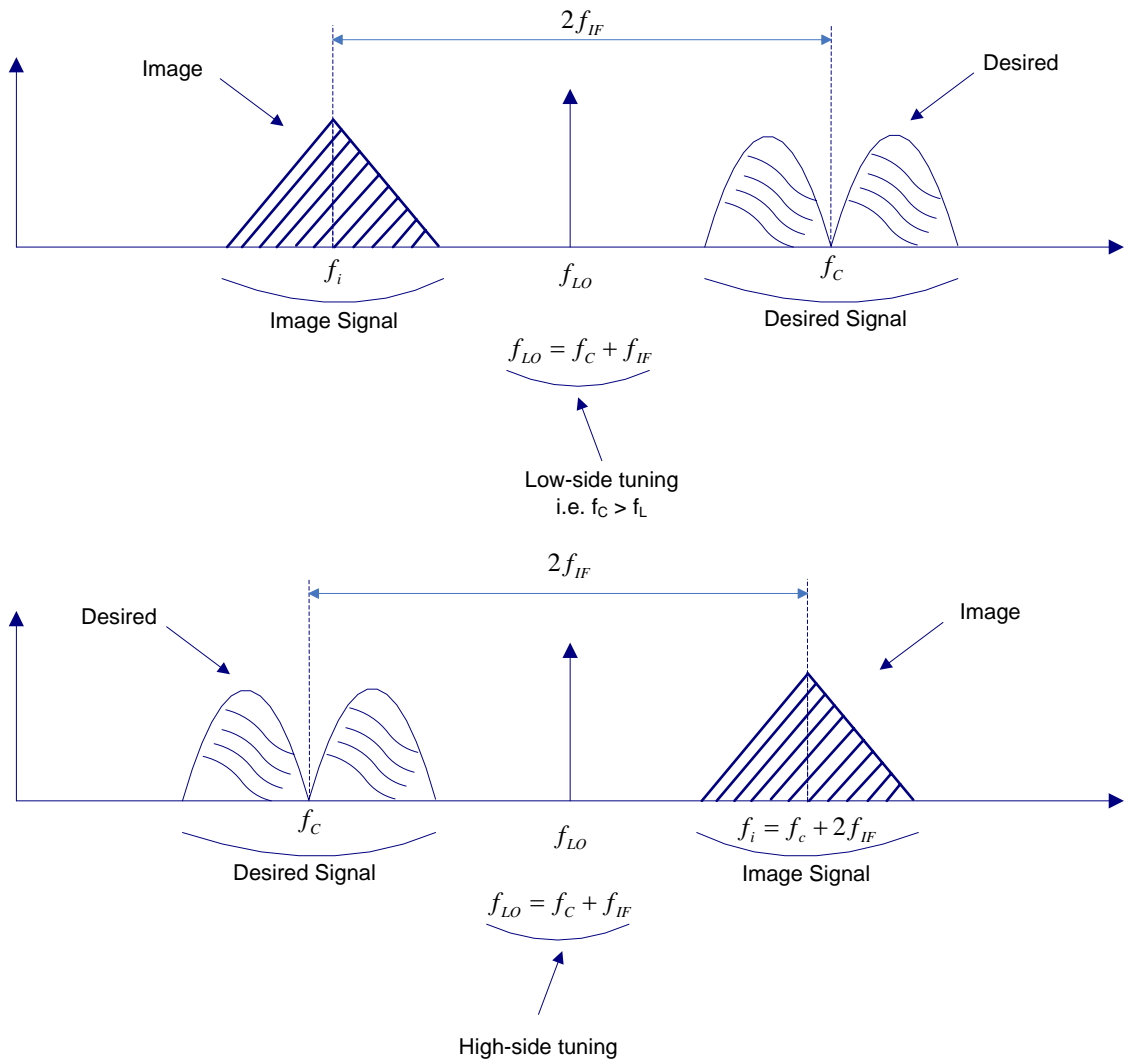

Fig 21.

Illustration of image frequency high-side tuning (i.e. $f_{LO} = f_c + f_{IF}$)

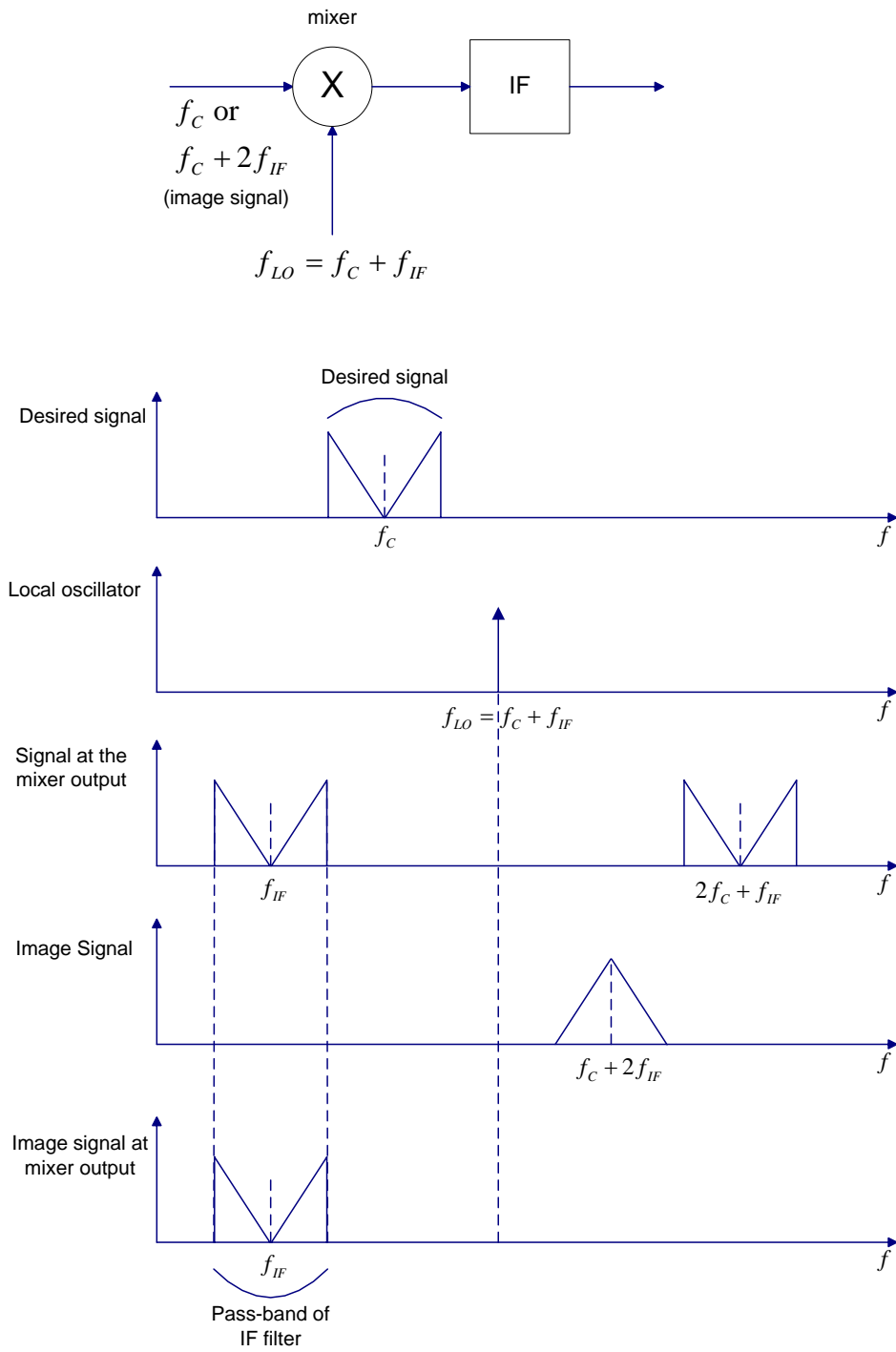
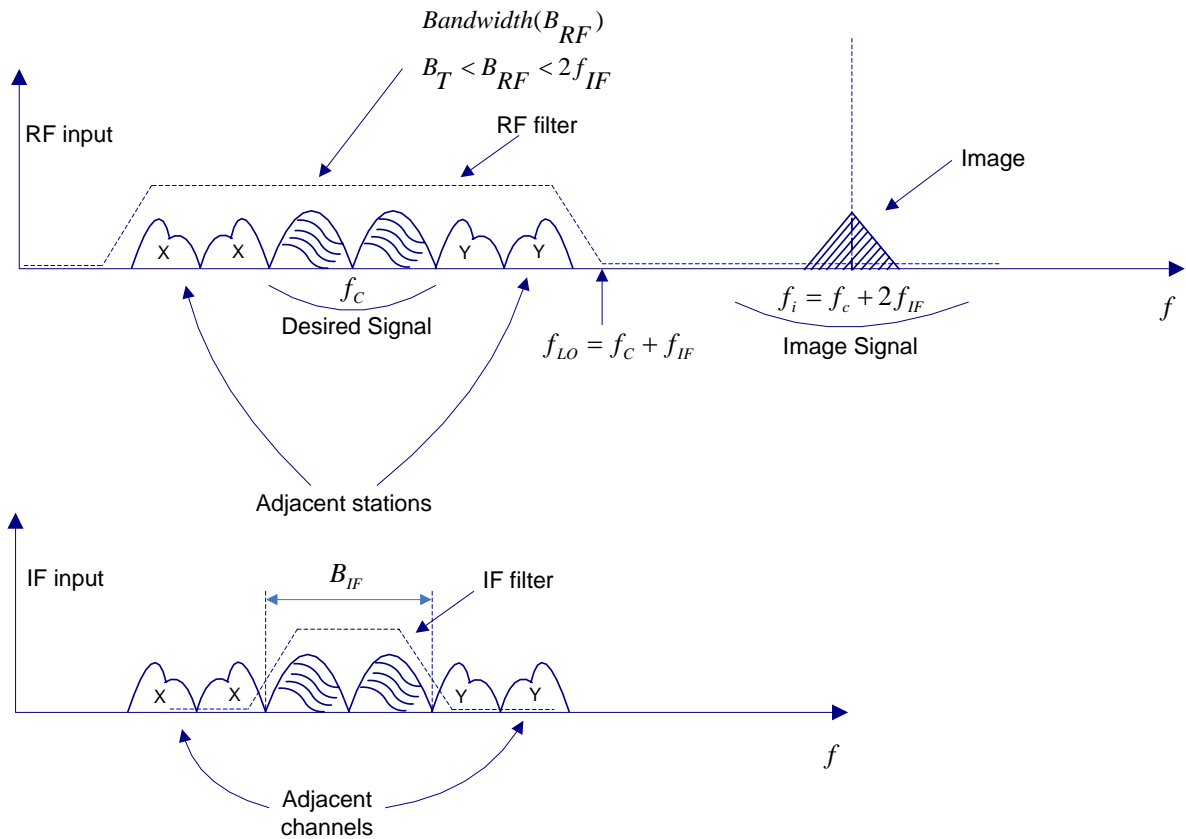

Fig 22.

Fig 22 shows the desired signal and the image signal for a local oscillator having the frequency $f_{LO} = f_c + f_{IF}$.

The image frequency can be eliminated by the radio –frequency (RF) filter. Thus the image frequency is separated from the desired signal by almost 1 MHz when IF for AM radio is 455 KHz.

RF input spectrum



Bandwidth of IF \approx Bandwidth of Transmission (BT)

- Adjacent channels are rejected.

Superheterodyne AM receiver:

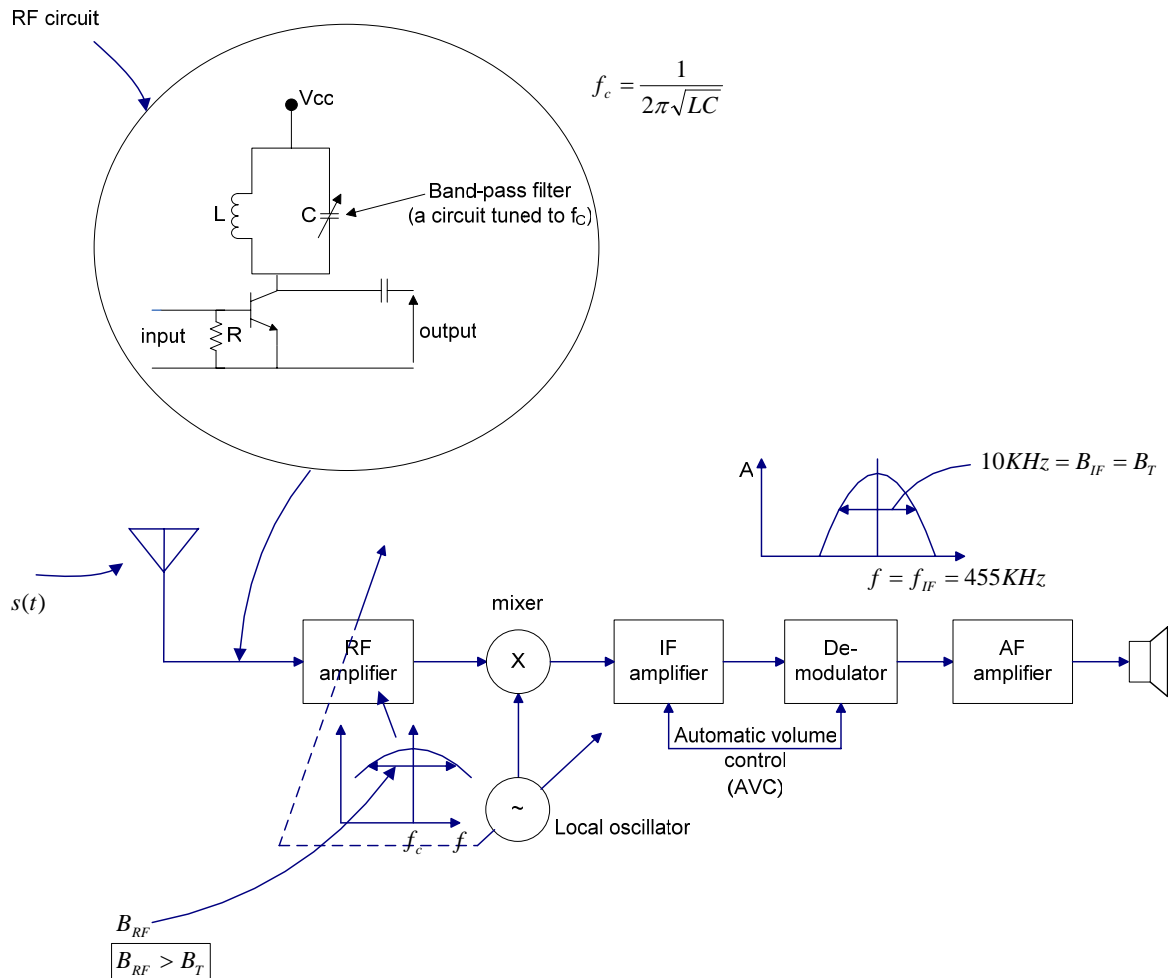

The superheterodyne structure results in several practical benefits:

- First tuning takes place entirely in the **'front'** end so the rest of the circuitry, including the demodulator requires **no adjustment** to change f_c .
- The separation between f_c and f_{IF} eliminates potential instability due to **stray feedback** from the amplified output to the receiver's input.
- Most of the gain and selectivity is concentrated in the IF stage.

The centre frequency selected for the IF amplifier is chosen on the basis of three considerations:

- The IF should be such that a stable high-gain IF amplifier can be economically attained.
- The IF frequency needs to be low enough so that, with practical circuit elements in the IF filters provide a steep attenuation characteristic outside the bandwidth of the IF signal. This decreases the noise and minimises the interference from adjacent channels.
- The IF frequency needs to be high enough so that the receiver image response can be made very small.

The local oscillator tuning ratio:

For example, with AM broadcast radio, where $540 < f_c < 1600$ KHz and $f_{IF} = 455$ KHz. using

$$f_{LO} = f_c + f_{IF}$$

Resulting in

$$995 \text{ KHz} < f_{LO} < 2055 \text{ KHz}$$

And thus a local oscillator tuning range of 2:1. (i.e. $2055/995 \approx 2/1$).

On the other hand, if we choose $f_{LO} = f_c - f_{IF}$ then for the same IF and input frequency range,

We get

$$85 < f_{LO} < 1145 \text{ KHz}$$

Or a local oscillator tuning range of 13:1 (i.e. $1145/85$)

Note:

If $f_{LO} > f_c$ the sideband of the IF output will be inverted (i.e. upper-side band on the RF input will become the lower-side band etc.)

If $f_{LO} < f_c$, the side bands are not inverted.

Automatic gain control

Superheterodyne receivers often contain an automatic gain control (AGC) such that the receiver's gain is automatically adjusted according to the input signal level.

AGC is accomplished by rectifying the receiver's audio signal, thus calculating the average value.

This dc Value is then fed to the IF (or RF) stage to increase or decrease the stages gain. An AM radio usually includes an automatic volume control (AVC) signal from Demodulator back to the IF (see Fig20, page93).

Example

Consider a block diagram of the mixer of a superheterodyne receiver.

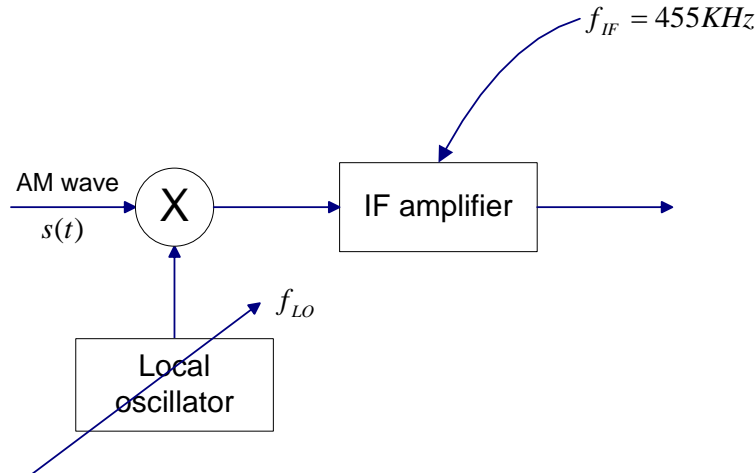

The input signal is an AM wave of bandwidth 10 KHz and the carrier frequency that may lie anywhere in the range 535 KHz to 1605KHz. It is then required to translate this signal to a frequency band centred at a tuned IF of 455 KHz.

Find the range of tuning that must be provided in the local oscillator in order to achieve this requirement. You may assume low-side tuning.

Let f_{LO} be the local oscillator frequency;

$$f_{LO} = f_c - f_{IF} \quad (\text{Low-side tuning})$$

When $f_c = 535\text{KHz}$

$$f_{LO} = 0.535 - 0.455 \text{ MHz} = 80 \text{ KHz}$$

When $f_c = 1605\text{KHz}$

$$f_{LO} = 1.605 - 0.455 \text{ MHz} = 1150 \text{ KHz}$$

Thus the required range of tuning of the local oscillator is 80 KHz to 1150KHz independent of the AM signal bandwidth.

Example

A superheterodyne receiver with $f_{IF} = 455\text{KHz}$ and $3500\text{KHz} < f_{LO} < 4000\text{KHz}$ has a tuning dial calibrated to receive signals from 3 to 3.5MHz. The receiver is set to receive a 3 MHz signal. The receiver has a broadband RF amplifier and it has found that the local oscillator has a **significant** 3rd harmonic component output.

If a signal is heard, what are all its possible carrier frequencies?

(You may assume upper-side tuning).

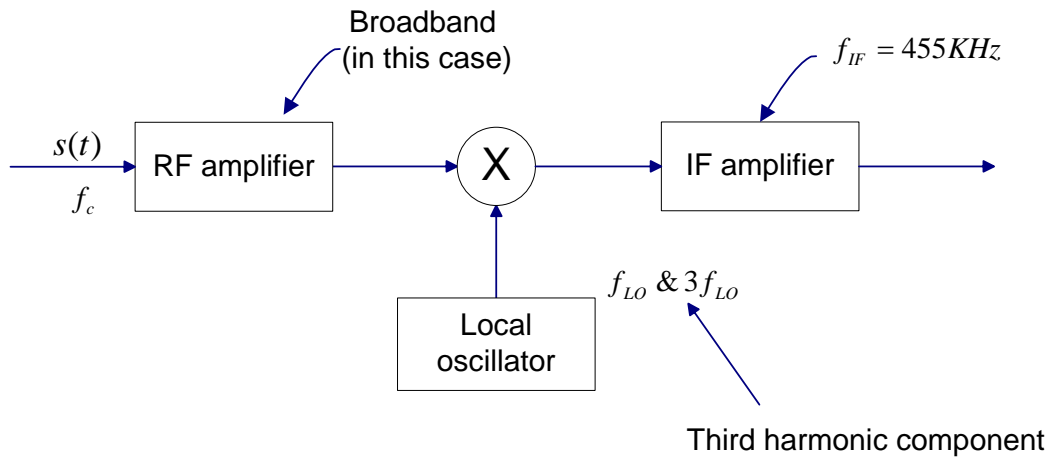

If f_c is set to 3.0 MHz (given) then $f_{LO} = f_c + f_{IF} = 3.0 + 0.455 = 3.455 \text{ MHz}$

Image frequency $f_i = f_c + 2f_{IF}$ (Page98_fig21)

$$f_i = 3.0 + 2(0.455) \quad \text{possible carrier}$$

$$\boxed{f_i = 3.91 \text{ MHz}} \quad \leftarrow \text{Frequency}$$

But the oscillators 3rd harmonic component is $3 \times f_{LO} = 10.365 \text{ MHz}$

$$\therefore f'_c = 3f_{LO} - f_{IF} = 10.365 - 0.455 = 9.910 \text{ MHz} \quad \leftarrow \text{Possible carrier frequency}$$

Corresponding image frequency is

$$f'_i = f'_c + 2f_{IF} = 9.910 + 2(0.455) = 10.820 \text{ MHz}$$

With this receiver, even though the dial states the received station is 3.0MHz, it may also receive 3.91MHz, 9.910MHz, and 10.820MHz.

Note: AM broadcast technical standard.

In US, the federal communication commission (FCC) technical standard for AM broadcast stations are shown below:

- assigned Frequency, f_c In 10KHz increments from 540 to 1700KHz
- channel bandwidth 10 KHz
- carrier frequency stability $\pm 20\text{Hz}$ of the assigned frequency
- clear channel frequencies 640 650 660 670,1,020,.....
(50KW stations, non directional) 1, 100,and 1210 KHz, etc.
- maximum power licensed 50 KW
(These stations united to cover areas, operated day and night)

Phase –locked loops (PLL)

A phase-locked loop (PLL) consists of three basic components:

- (1) A phase detector
- (2) A low pass filter
- (3) A voltage controlled oscillator (VCO) as shown in Fig23.

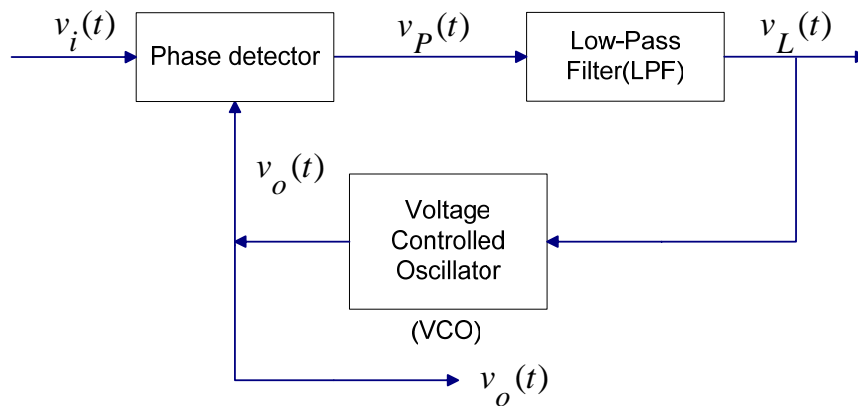

Fig 23.

The **(VCO)** is an oscillator that produces a periodic waveform with a frequency that may be varied about some free-running frequency f_o .

f_o – is the frequency of the VCO output when the applied voltage $v_i(t) = 0$.

The **phase detector** produces an output signal $v_p(t)$ that is a function of the phase difference between the incoming signal $v_i(t)$ and the oscillator signal $v_o(t)$.

The filtered signal output $v_L(t)$ is the control signal that is used to change the frequency of the VCO output.

If the applied signal has initial frequency of f_o , the PLL will acquire a **‘lock’** and the VCO will track the input signal frequency over some range, provided that the input frequency changes slowly.

However the loop will remain locked only over some finite range of frequency shift. This range is called hold-in (or lock –in) range.

The hold-in range depends on the overall dc gain of the loop, which includes the dc gain of the LPF.

On the other hand, if the applied signal has an initial frequency different from f_o , the loop may not acquire lock even though the input frequency is within the hold-in range. The frequency

range over which the applied input will cause the loop to lock is called the pull-in (or capture) range.

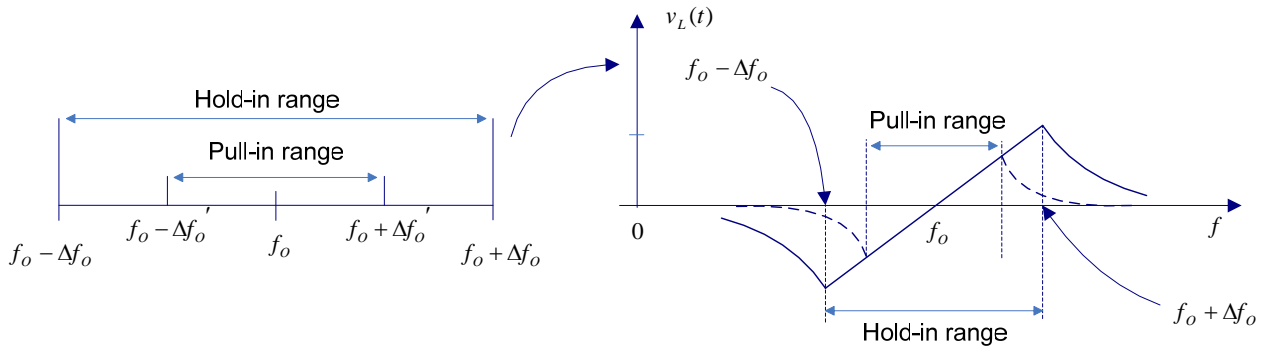

The pull-in range is determined primarily by the loop filter characteristics and it is never greater than hold-in range.

Another important PLL specification is the maximum **locked sweep rate** which is defined as the maximum rate of change of the input frequency for which the loop will remain locked.

If the input frequency changes faster than this rate, the loop will drop out of lock.

The PLL uses a multiplier as a **phase detector**.

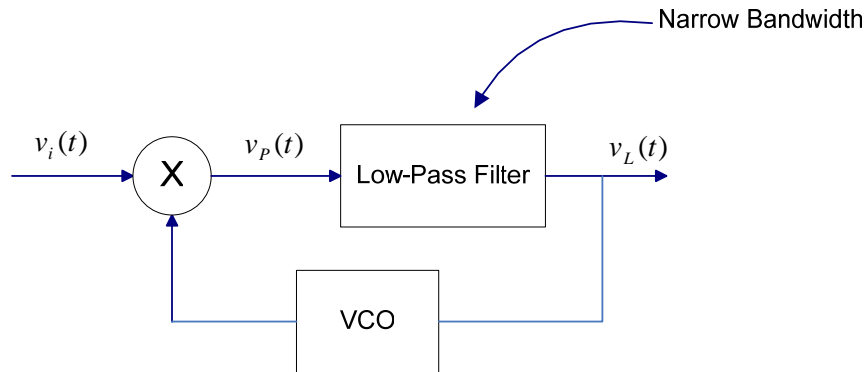

Assume that the input signal is:

$$v_i(t) = A_i \sin(\omega_0 t + \theta_i(t)) \quad (40)$$

And that the VCO output signal is:

$$v_o(t) = A_0 \cos(\omega_0 t + \theta_0(t)) \quad (41)$$

where $\theta_0(t) = K_v \int_0^t v_L(\tau) d\tau \quad (42)$

K_v is the VCO gain constant (radians per second unit input)

$$v_P(t) = k_m A_i A_o \sin(\omega_0 t + \theta_i(t)) \cdot \cos(\omega_0 t + \theta_o(t)) = \frac{k_m A_i A_o}{2} \sin(\theta_i(t) - \theta_o(t)) + \frac{k_m A_i A_o}{2} \sin(2\omega_0 t + \theta_i(t) + \theta_o(t)) \quad (43).$$

Where k_m is the gain of the multiplier circuit.

The sum frequency term does not pass through the LPF, so the LPF output

$$v_L(t) = \underbrace{\left(\frac{k_m A_i A_o}{2} \right)}_{\substack{= k_d \\ \text{Constant}}} \cdot \underbrace{\sin(\theta_i(t) - \theta_o(t))}_{\text{Phase error } \theta_e(t)}$$

When the PLL is operating in lock the phase error $\theta_e \approx 0$ (or very small)

$$\therefore \theta_i(t) = \theta_o(t)$$

\therefore The VCO phase $\theta(t)$ is a good estimate of the input-phase deviation $\theta_i(t)$.

Costas loop

Figure 22 below may be used to demodulate the DSB.SC signal. (Note an ordinary PLL cannot be used because there are no components at $\pm f_c$ – carrier suppressed).

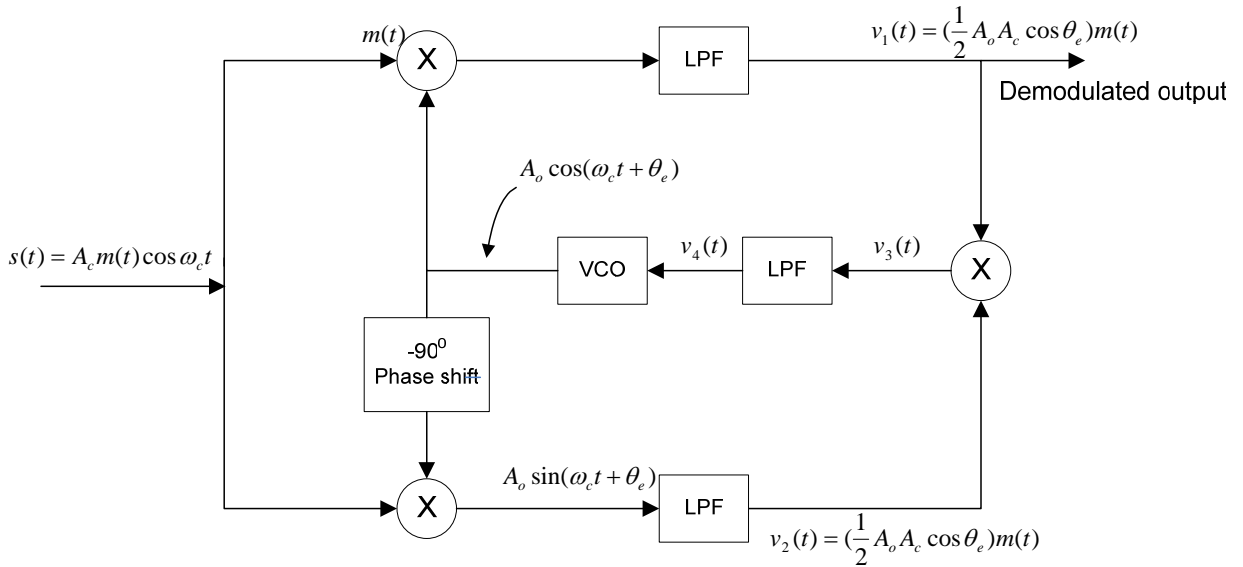

The Costas PLL is analysed by assuming that the VCO locked to the input suppressed carrier frequency f_c with a constant phase error of θ_e , then the voltage

$v_1(t)$ and $v_2(t)$ are obtained at the output of the lowpass filters as shown above.

Since θ_e is small, the amplitude of $v_1(t)$ is relatively large compared to that of $v_2(t)$ (i.e. $\cos \theta_e \gg \sin \theta_e$).

Furthermore $v_1(t)$ is proportional to $m(t)$ so it is the demodulated output.

$$v_3(t) = v_1(t) \cdot v_2(t)$$

$$= \frac{1}{2} \left(\frac{1}{2} A_o A_c \right)^2 m^2(t) \sin 2\theta_e$$

The voltage $v_3(t)$ is filtered with an LPF that has a cut-off frequency near dc so that this filter acts as an integrator to produce the dc for the VCO,

$$V_4(t) = K \sin 2\theta_e \text{ where } k = \frac{1}{2} \left(\frac{1}{2} A_o A_c \right)^2 \langle m^2(t) \rangle \text{ average. i.e DC level of } m^2(t)$$

The dc control voltage is significant to keep the VCO locked to f_c with a small phase error θ_e .